

# bucket elevators

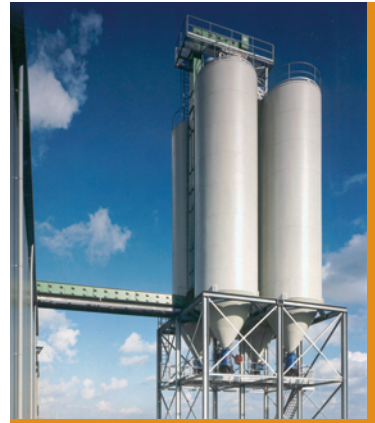

INTERNOVI has been the ultimate supplier of vertical transport systems such as lifts and bucket elevators for a very long time. INTERNOVI particularly delivers bucket elevators for all bulk goods that have to remain undamaged during vertical transport. These bucket elevators are applied in a wide range of industries: from pharmacy, food, animal feed to building materials and chemical products.

# bucket elevators

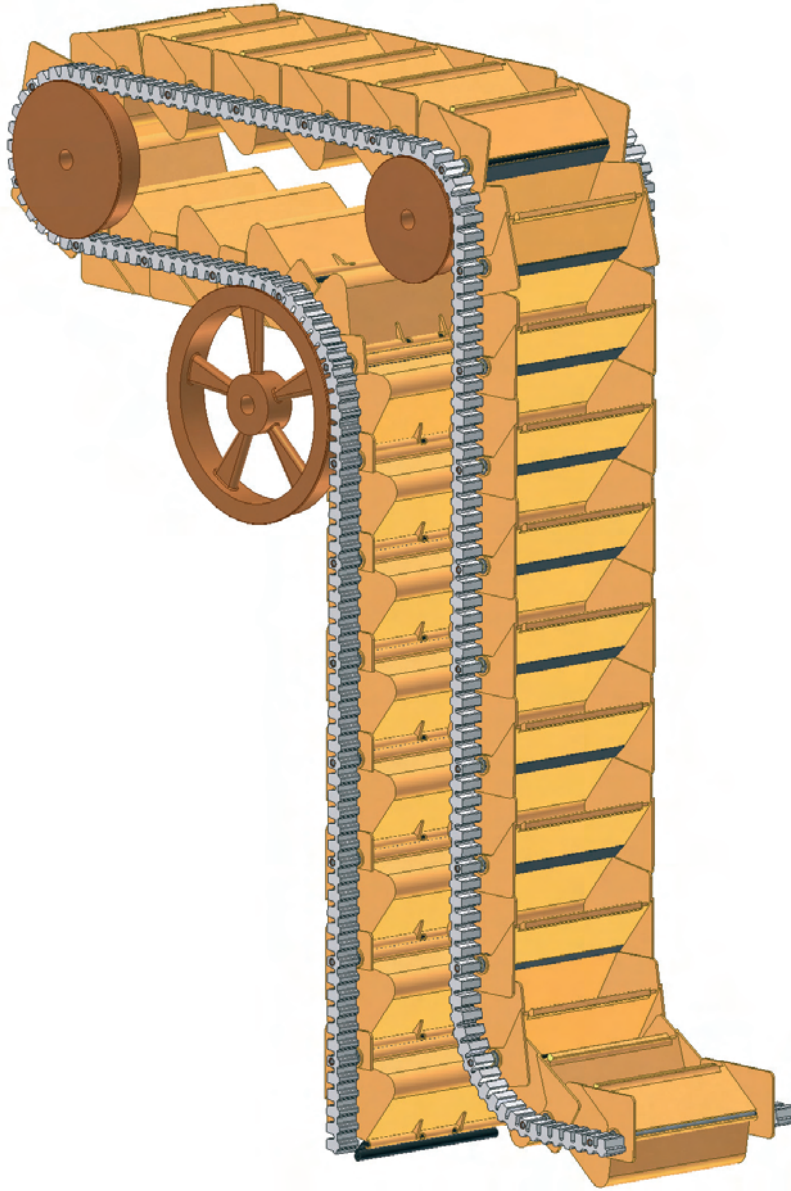
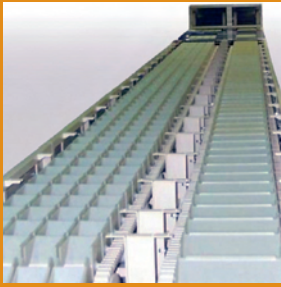

Each bulk good is different and has its own problems and properties. By combining your knowledge and experience in this field with our knowledge and experience in internal transport, we can always offer you a customer-made solution. Our serially produced components form the basis for the made-to-measure project in the final execution.

The points of departure of the basic design and the materials applied make the pendulum bucket elevator of Internovi extremely suitable. The application requirements vary from none to hygienic, explosion-hazardous, gastight, heat resistant and silent.

## Buckets

The buckets are made from various plastics, aluminium or stainless steel and are interconnected by a plastic flap to form a continuous belt. This type is often applied in continuous industry and they can be manually cleaned with water or air or automatically by means of a built-in nozzle system.

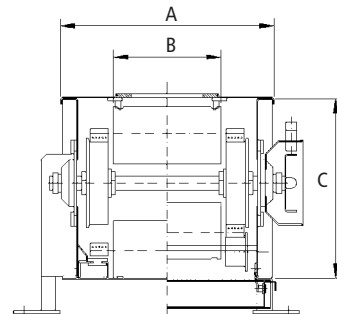

TYPE	SEB 03	WB 130	WB 250	SEB 1	WB 300	SEB 2	WB 370	SEB 5	WB 640
Capacity m <sup>3</sup>	5	6	10	15	20	25	45	50	100
Bucket volume ltr	0,3	0,36	0,7	1,7	2,1	3	4	6,5	11
Dimensions A	350	350	500	600	600	700	700	800	800
Bucket width B	120	130	250	205	300	270	370	375	640
Dimensions C	350	350	350	500	500	600	600	750	750

*All given dimensions are to be interpreted as being approximate. Changes in dimensions reserved. Exact dimensions per type are available on request.*

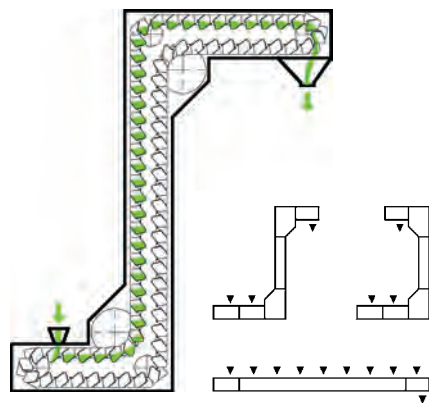

## Configurations

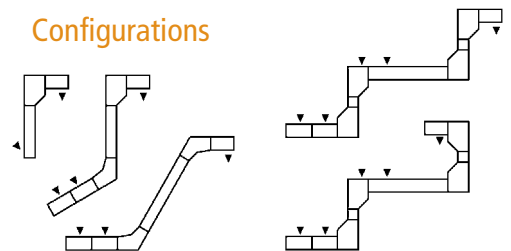

## Rubber block chain

All machines may be equipped with steel chains, but we prefer the rubber block chain.

Advantages of the rubber block chain are:

- Silent
- Wear-resistant and maintenance-free
- Very large tensile force because of steel cables
- Minimum elongation, no need to tension the chain
- No guides where product residues remain behind
- Simple removal of buckets and cleaning
- Low use of energy



Hanzestraat 12b, 7622 AX Borne (O)  
 P.O. Box 187, 7620 AD Borne (O), Holland  
 Phone: (31) 74 - 266 60 06  
 Fax: (31) 74 - 266 23 05  
 Email: [internovi@internovi.nl](mailto:internovi@internovi.nl)  
 Internet: [www.internovi.nl](http://www.internovi.nl)

*Transport systems with this specific rubber block chain have been delivered for over 40 years. You will find our systems in a wide range of industries. We deliver bucket elevators, pendulum bucket elevators, continuous lifts, discontinuous lifts, pallet lifts, lifts for luggage and containers, air conveyors and golland conveyors. With our own engineering and service departments and your specific product knowledge we provide a custom-made solution varying from one machine to complete turnkey projects.*